

PennBarry

General Wiring Instructions

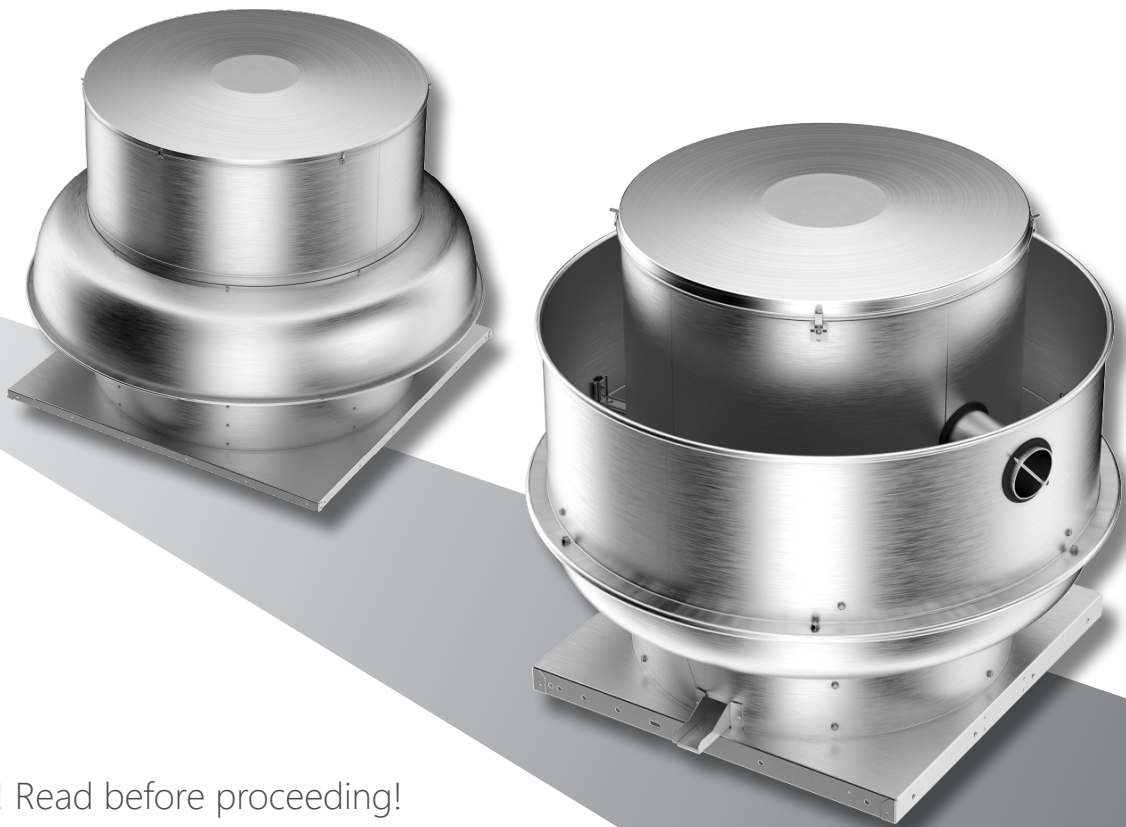

IMPORTANT! Read before proceeding!

The information contained herein is, to the best of our knowledge, accurate and applicable for proper operation and installation of the specified equipment at the time this document entered service. Before proceeding, it is recommended that you check for a more current version of this Installation Operation Manual (IOM) on our website at www.pennbarry.com. Read carefully before attempting to assemble, install, operate or maintain the product described. Protect yourself and others by observing all safety information. Failure to comply with instructions could result in personal injury and/or property damage! Retain instructions for future reference.

TABLE OF CONTENTS

SINGLE PHASE MOTOR – INSTALLED JUNCTION BOX	3
THREE PHASE MOTOR – INSTALLED JUNCTION BOX	3
SINGLE PHASE MOTOR – INSTALLED SERVICE SWITCH	4
THREE PHASE MOTOR – INSTALLED SERVICE SWITCH	4
SINGLE PHASE INPUT / THREE PHASE MOTOR – OPTIONAL DELTA SPEED CONTROLLER	5
SINGLE PHASE INPUT / THREE PHASE MOTOR – OPTIONAL VSC SPEED CONTROLLER	5
THREE PHASE INPUT / THREE PHASE MOTOR – OPTIONAL DELTA SPEED CONTROLLER	6
THREE PHASE INPUT / THREE PHASE MOTOR – OPTIONAL VSC SPEED CONTROLLER	6
SINGLE PHASE TYPE-A EC MOTOR - ONBOARD SPEED CONTROLLER	7
SINGLE PHASE TYPE-B EC MOTOR - ONBOARD SPEED CONTROLLER	7
SINGLE PHASE TYPE-A EC MOTOR - EXTERNAL SPEED CONTROLLER SIGNAL	8
SINGLE PHASE TYPE-B EC MOTOR - EXTERNAL SPEED CONTROLLER SIGNAL	8
SINGLE PHASE TYPE-B EC MOTOR CONNECTION DETAILS	9
SINGLE PHASE TYPE-A EC MOTOR - MULTI SPEED CONTROLLER (iQ-MS)	9
SINGLE PHASE TYPE-B EC MOTOR - MULTI SPEED CONTROLLER (iQ-MS)	10
SINGLE PHASE TYPE-A EC MOTOR - INTELLIGENT PRESSURE CONTROL MODULE (iQ-IPCM)	10
SINGLE PHASE TYPE-B EC MOTOR - INTELLIGENT PRESSURE CONTROL MODULE (iQ-IPCM)	11

SINGLE PHASE MOTOR – INSTALLED JUNCTION BOX

- FIELD WIRE BY OTHERS
- FACTORY WIRE
- ISOLATED WIRE NUT
- ◻ ISOLATED CRIMP CAP

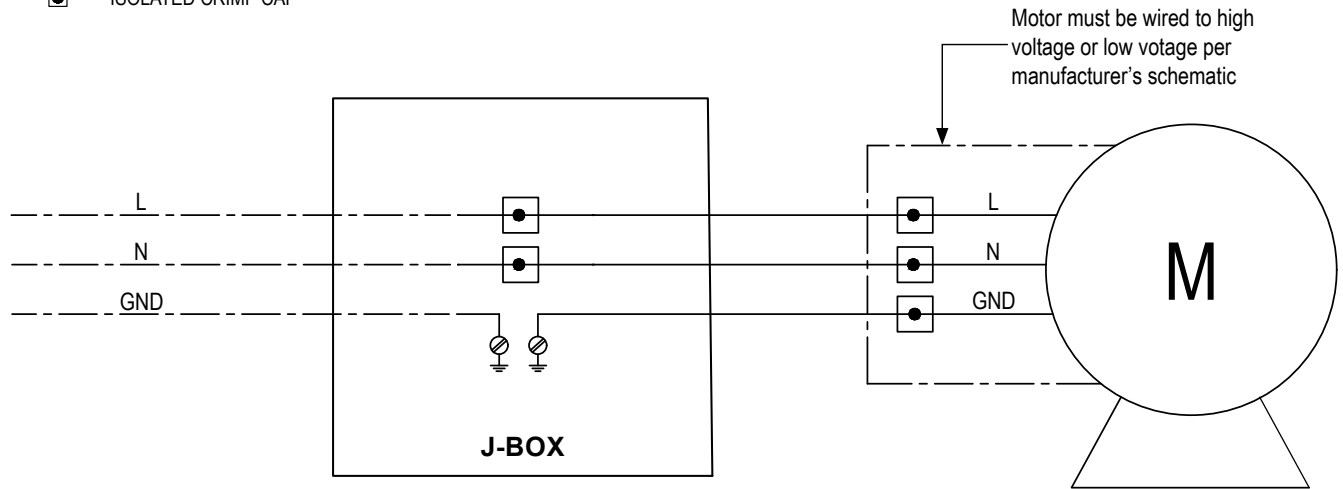

THREE PHASE MOTOR – INSTALLED JUNCTION BOX

- FIELD WIRE BY OTHERS
- FACTORY WIRE
- ISOLATED WIRE NUT
- ◻ ISOLATED CRIMP CAP

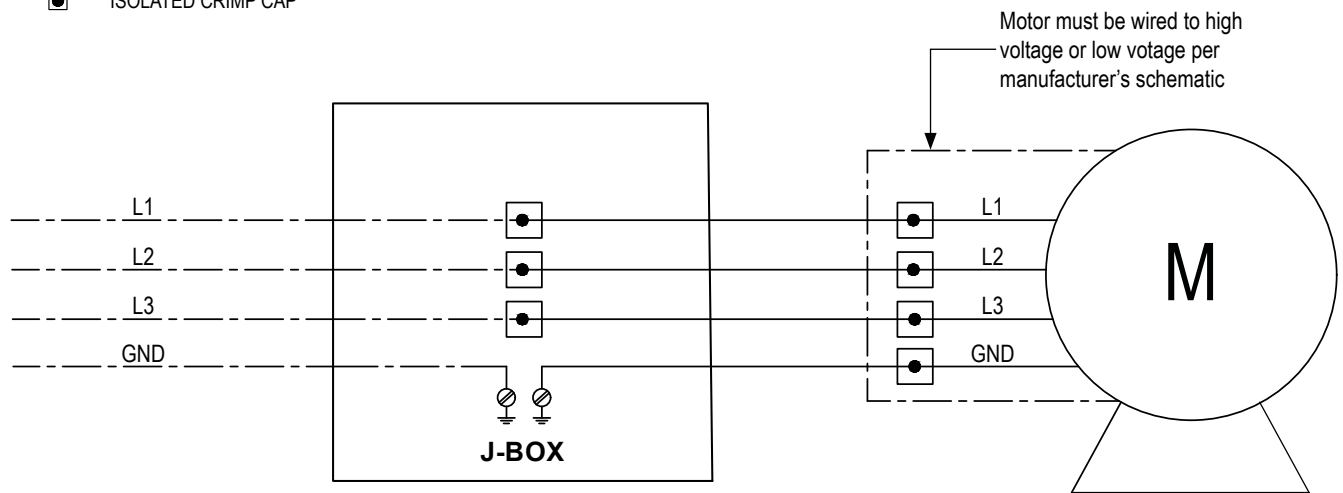

SINGLE PHASE MOTOR – INSTALLED SERVICE SWITCH

- FIELD WIRE BY OTHERS
- FACTORY WIRE
- ISOLATED WIRE NUT
- ◻ ISOLATED CRIMP CAP

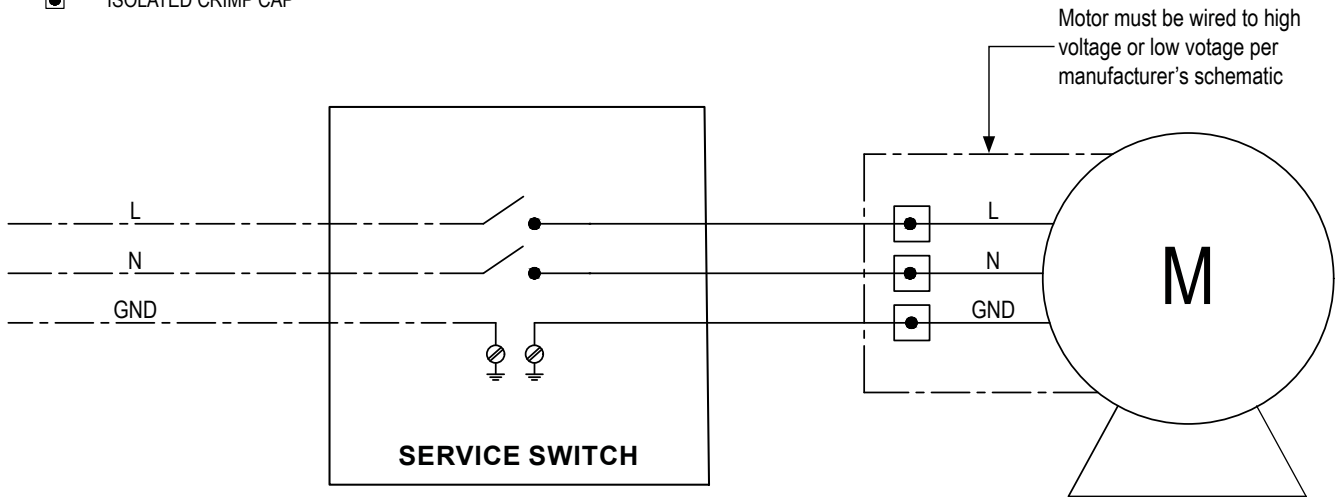

THREE PHASE MOTOR – INSTALLED SERVICE SWITCH

- FIELD WIRE BY OTHERS
- FACTORY WIRE
- ISOLATED WIRE NUT
- ◻ ISOLATED CRIMP CAP

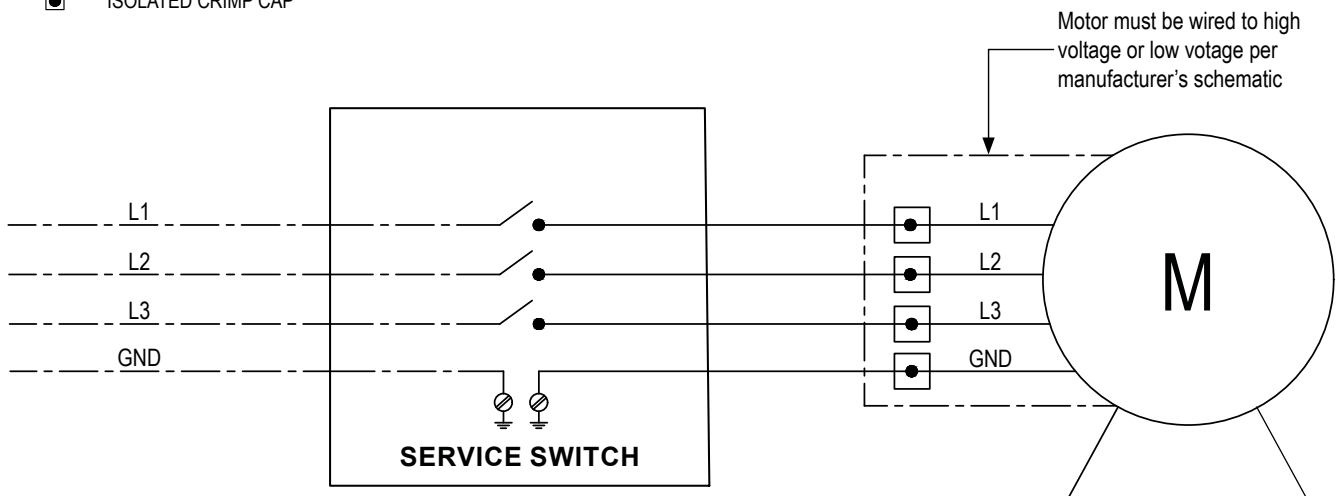

SINGLE PHASE INPUT / THREE PHASE MOTOR OPTIONAL DELTA SPEED CONTROLLER

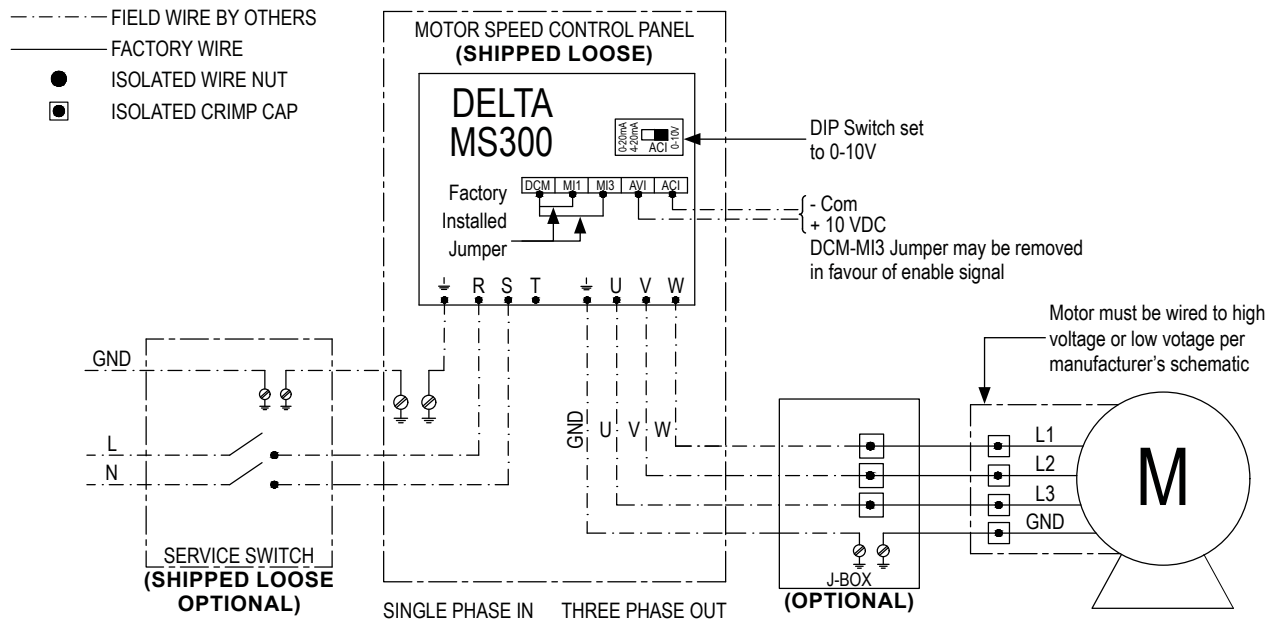

- Note. - 1. DCM-MI3 Jumper allows preset speed to run when power is on.
 2. DCM-MI1 Jumper = FWD.
 3. Factory mounted and wired speed controllers can also be ordered for select models.

SINGLE PHASE INPUT / THREE PHASE MOTOR OPTIONAL VSC SPEED CONTROLLER

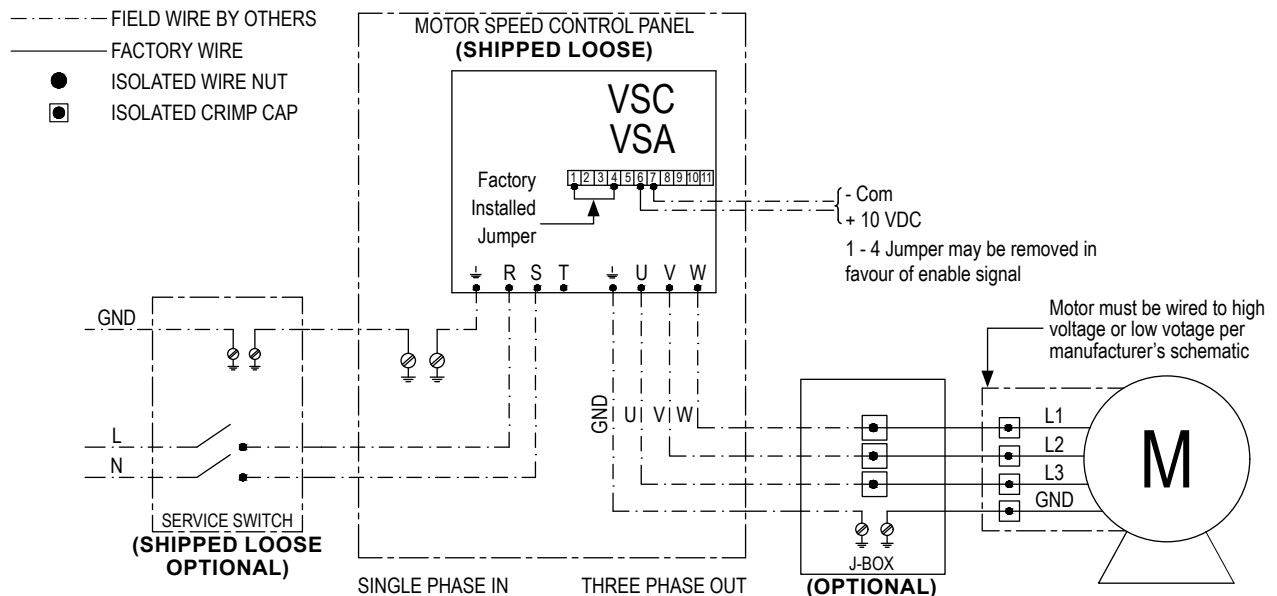

- Note. - 1. Factory mounted and wired speed controllers can also be ordered for select models.

THREE PHASE INPUT / THREE PHASE MOTOR OPTIONAL DELTA SPEED CONTROLLER

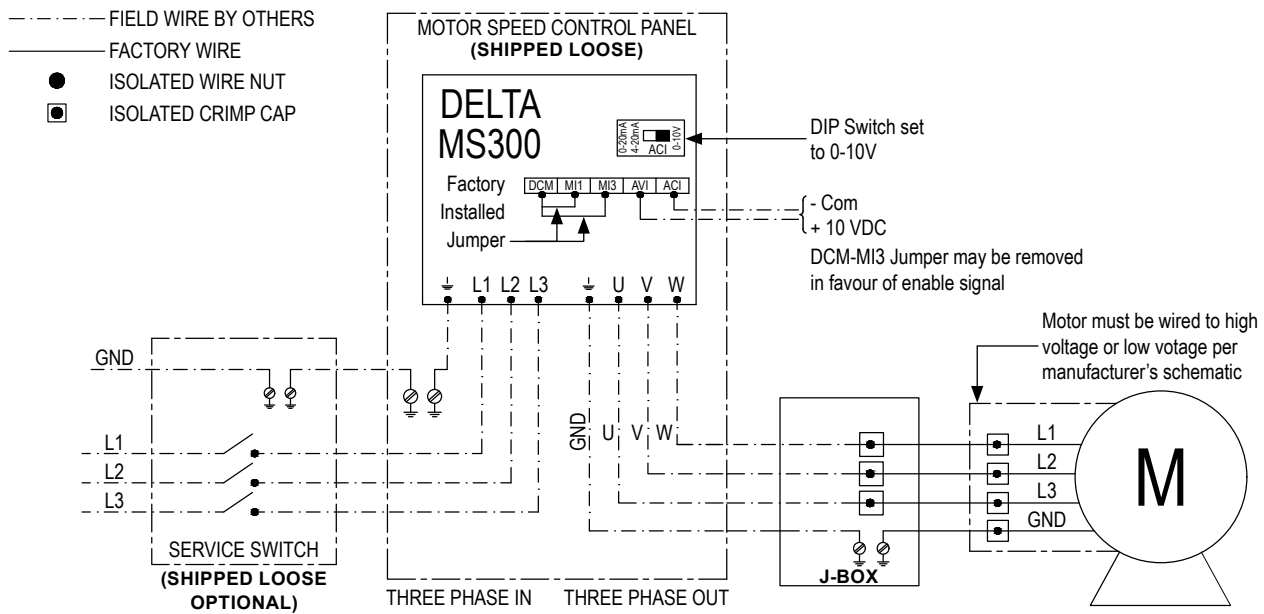

Note. - 1. DCM-MI3 Jumper allows preset speed to run when power is on.
 2. DCM-MI1 Jumper = FWD.
 3. Factory mounted and wired speed controllers can also be ordered for select models.

THREE PHASE INPUT / THREE PHASE MOTOR OPTIONAL VSC SPEED CONTROLLER

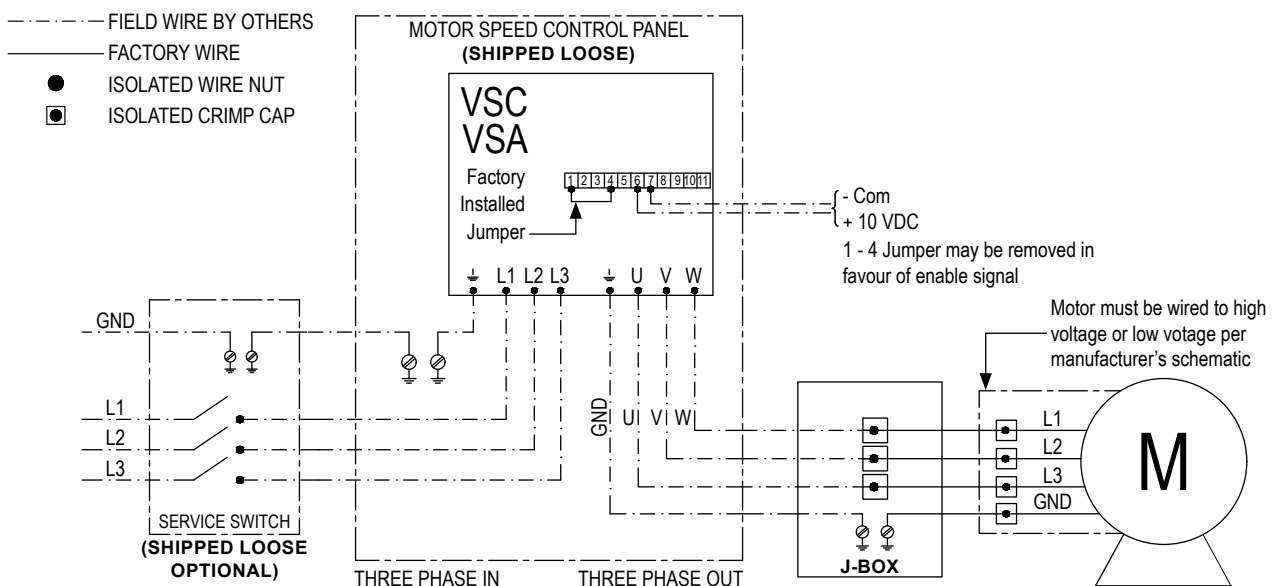

Note. - 1. Factory mounted and wired speed controllers can also be ordered for select models.

SINGLE PHASE TYPE-A EC MOTOR - ONBOARD SPEED CONTROLLER

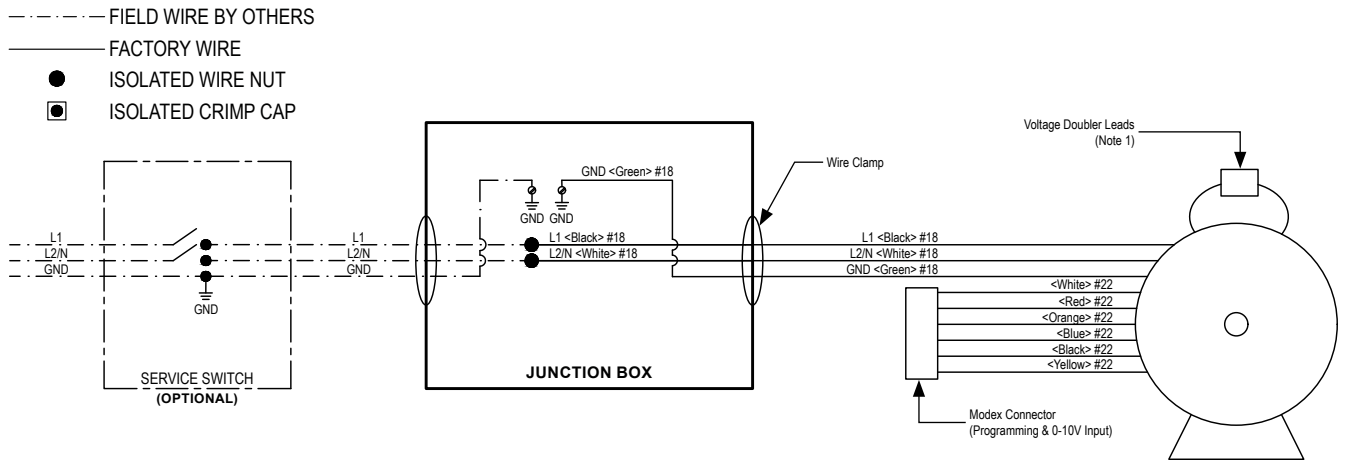

Note. - 1. Voltage Doubler Leads to be Connected only for 120V. Must be Disconnected when 208-277V is used.
 2. Motor's onboard speed controller can be used.

SINGLE PHASE TYPE-B EC MOTOR - ONBOARD SPEED CONTROLLER

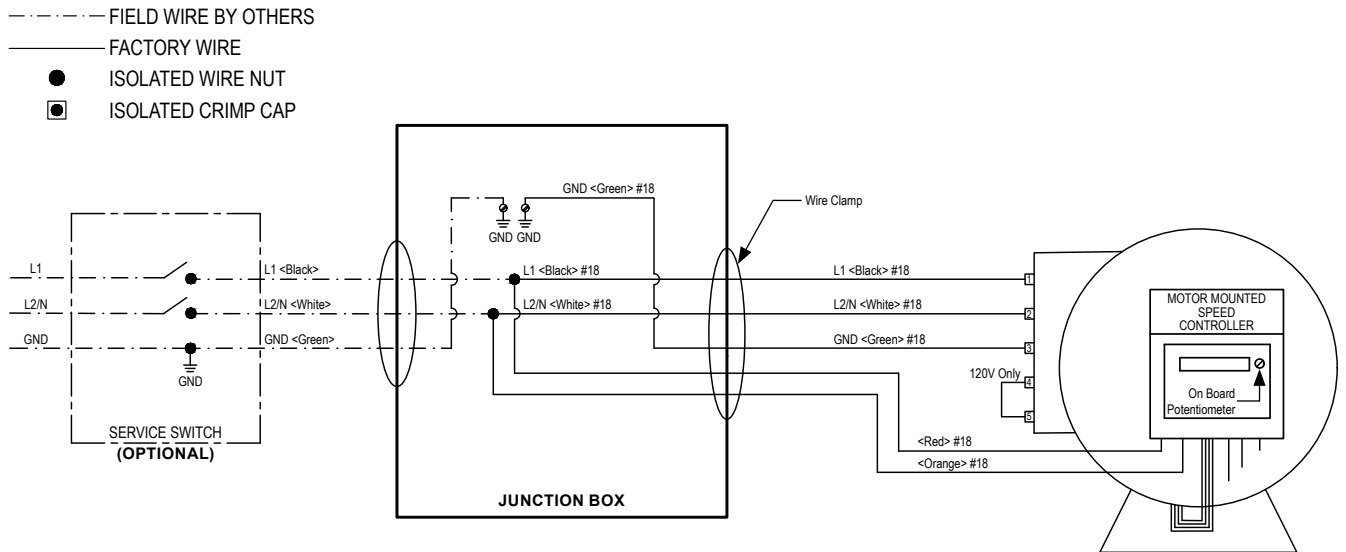

Note. - 1. Voltage Doubler Leads to be Connected only for 120V. Must be Disconnected when 208-277V is used.
 2. Motor's onboard speed controller can be used.

SINGLE PHASE TYPE-A EC MOTOR - EXTERNAL SPEED CONTROLLER SIGNAL

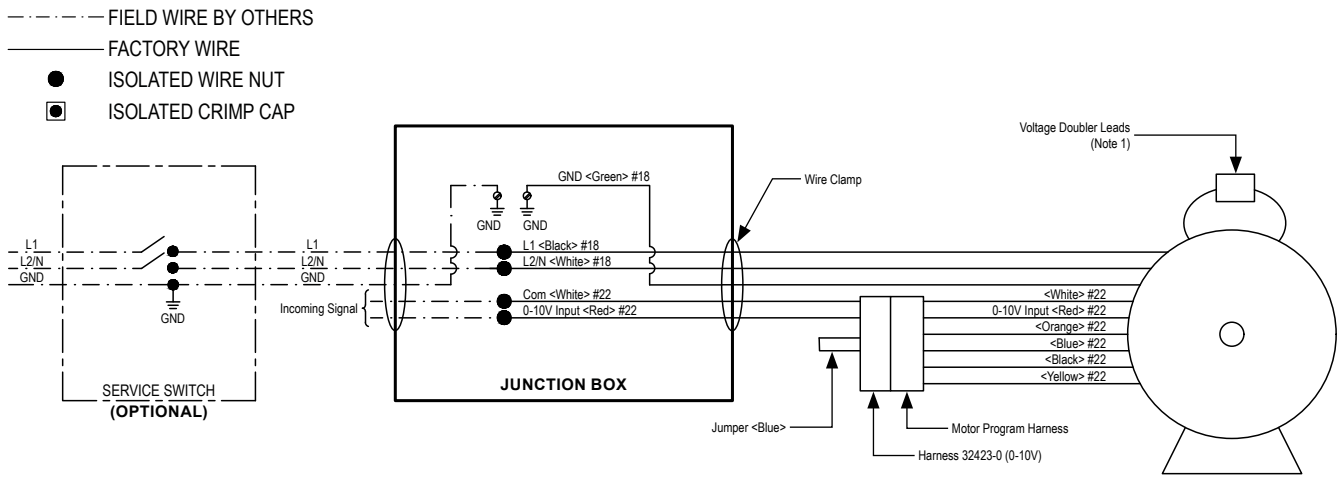

Note. - 1. Voltage doubler leads to be connected only for 120V. Must be disconnected when 208-277V is used.
 2. To Use External speed control, turn motor mounted potentiometer fully clockwise (100%).
 3. For wiring instruction of external speed controller refer OEM catalog.

SINGLE PHASE TYPE-B EC MOTOR - EXTERNAL SPEED CONTROLLER SIGNAL

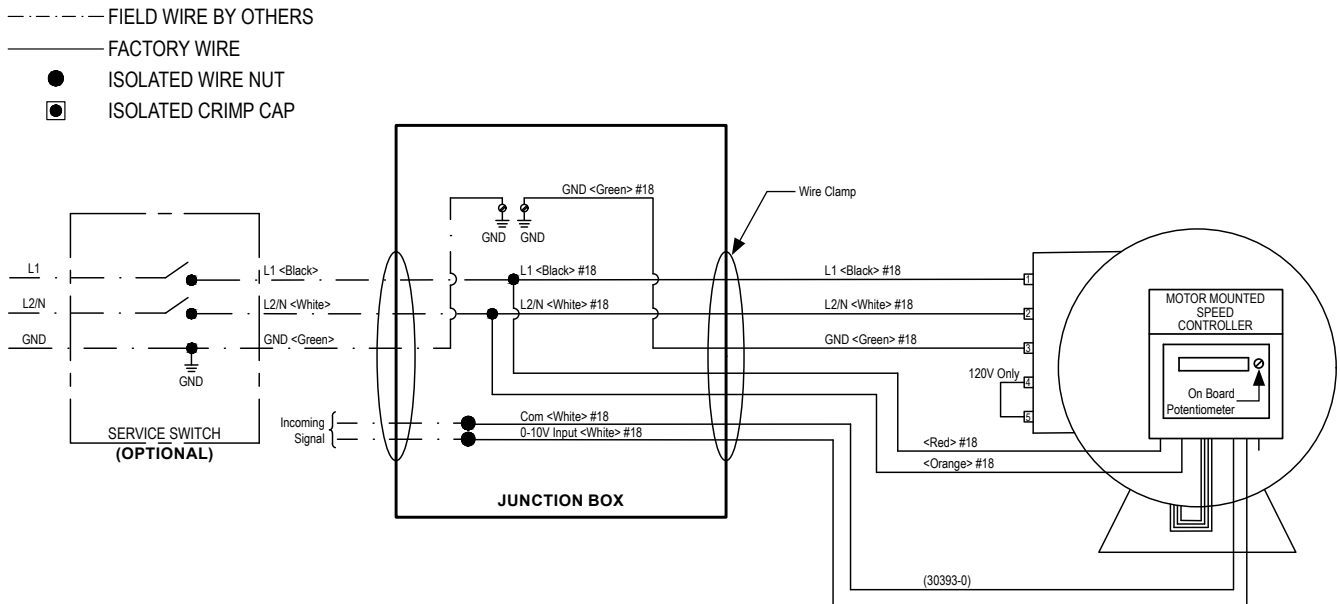

Note. - 1. Voltage doubler leads to be connected only for 120V. Must be disconnected when 208-277V is used.
 2. To Use External speed control, turn motor mounted adjustment screw fully counter-clockwise (0%).
 3. For wiring instruction of external speed controller refer OEM catalog.

SINGLE PHASE TYPE-B EC MOTOR CONNECTION DETAILS

REMOTE INPUT
(30393-0 HARNESS PROVIDED BY PENNBARRY)



REMOTE POTENTIOMETER
(PROVIDED BY OTHERS)

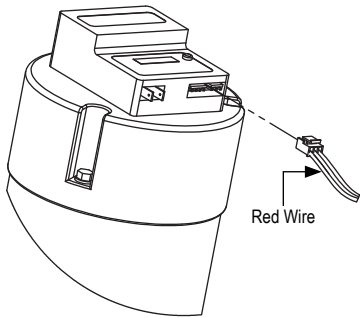
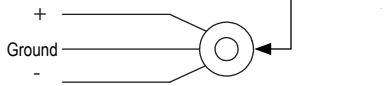

115V - 120V SINGLE PHASE

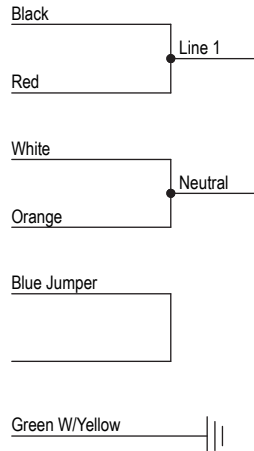

OPERATION

The blue on-board speed adjust knob sets the motor's minimum speed. The external signal (0-10VDC or potentiometer) controls the remaining speed range.

EXAMPLE: On-board speed adjust knob set to 25%. External signal controls remaining 75% of motors speed range.

EXAMPLE: On-board speed adjust knob set fully ccw (off). External signal controls entire motor speed range.

EXAMPLE: External signal removed. On-board speed adjust knob controls entire motor speed range.

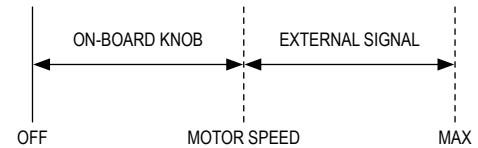

SINGLE PHASE TYPE-A EC MOTOR - MULTI SPEED CONTROLLER (iQ-MS)

- FIELD WIRE BY OTHERS
- FACTORY WIRE
- ISOLATED WIRE NUT
- ISOLATED CRIMP CAP

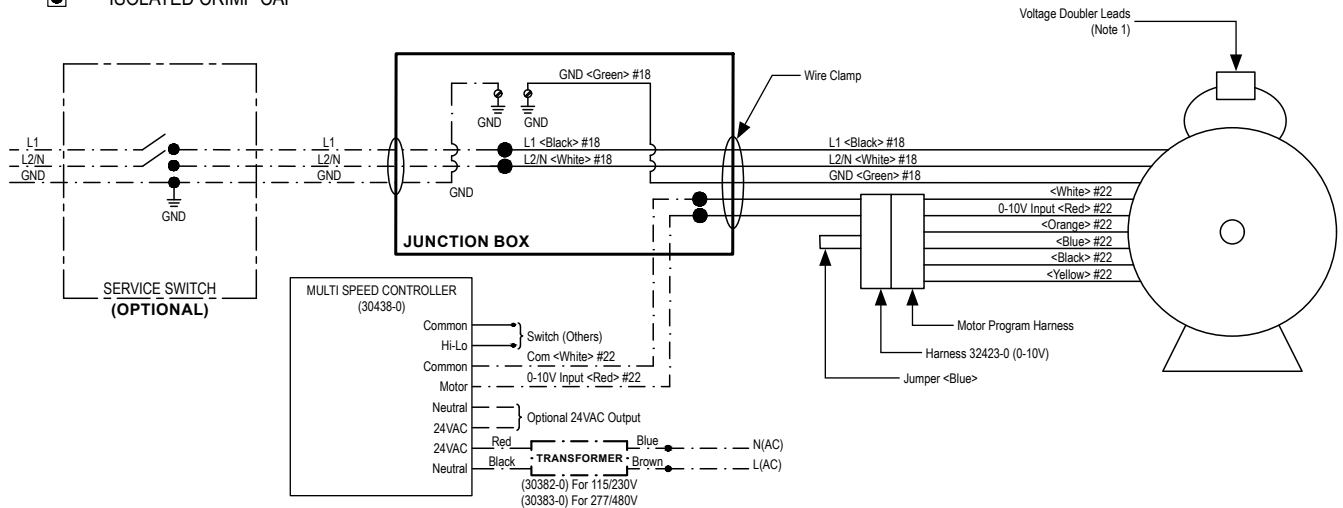

- Note. - 1. Voltage doubler leads to be connected only for 120V. Must be disconnected when 208-277V is used.
 2. To Use External speed control, turn motor mounted potentiometer fully clockwise (100%).
 3. For wiring instructions of external speed controller refer OEM catalog.
 4. Multi-speed controller can be purchased with or without a power supply.

SINGLE PHASE TYPE-B EC MOTOR - MULTI SPEED CONTROLLER (iQ-MS)

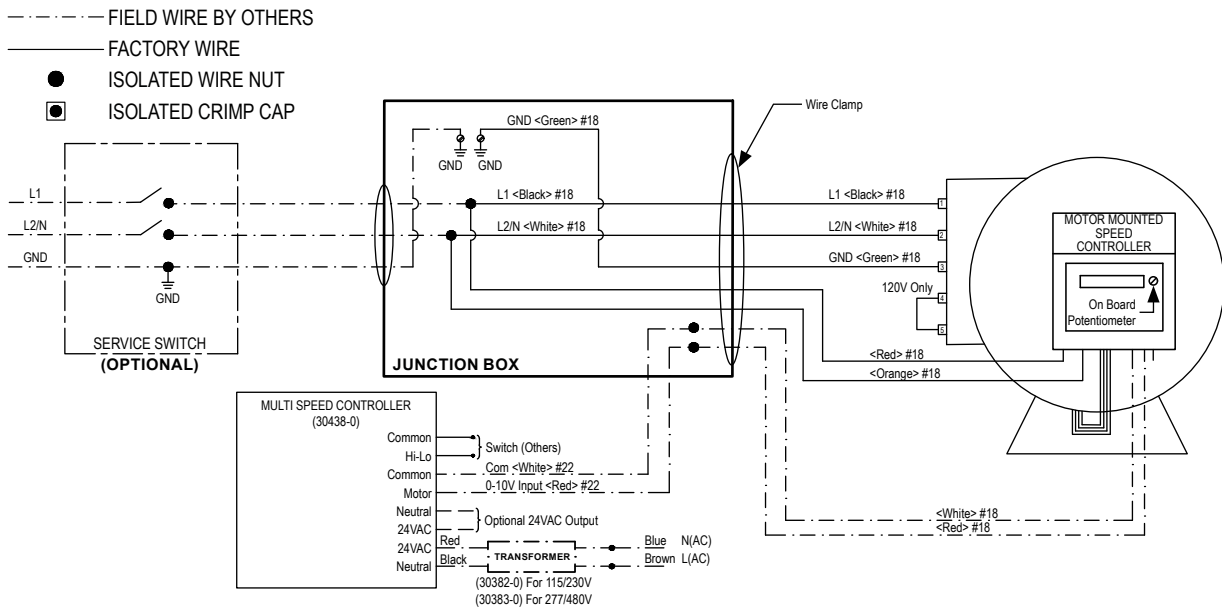

- Note. - 1. Voltage doubler leads to be connected only for 120V. Must be disconnected when 208-277V is used.
 2. To Use External speed control, turn motor mounted adjustment screw fully counter-clockwise (0%).
 3. For wiring instructions of external speed controller refer OEM catalog.
 4. Multi-speed controller can be purchased with or without a power supply.

SINGLE PHASE TYPE-A EC MOTOR - INTELLIGENT PRESSURE CONTROL MODULE (iQ-IPCM)

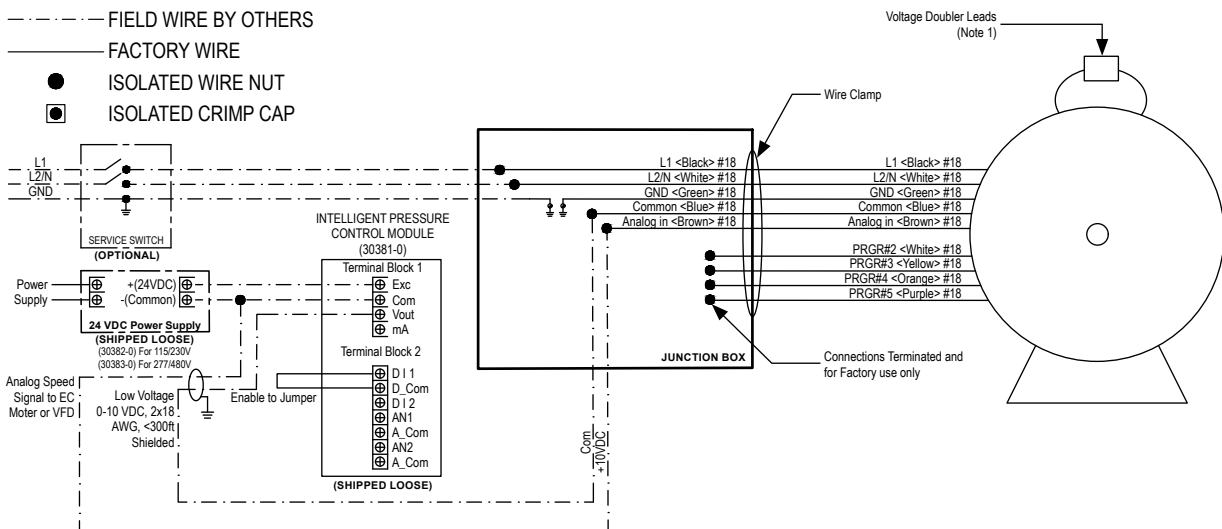

- Note. - 1. Voltage doubler leads to be connected only for 120V. Must be disconnected when 208-277V is used.
 2. To Use External speed control, turn motor mounted adjustment screw fully counter-clockwise (100%).
 3. For wiring instructions of external speed controller refer OEM catalog.
 4. Intelligent pressure controller can be purchased with or without a power supply.

SINGLE PHASE TYPE-B EC MOTOR - INTELLIGENT PRESSURE CONTROL MODULE (iQ-IPCM)

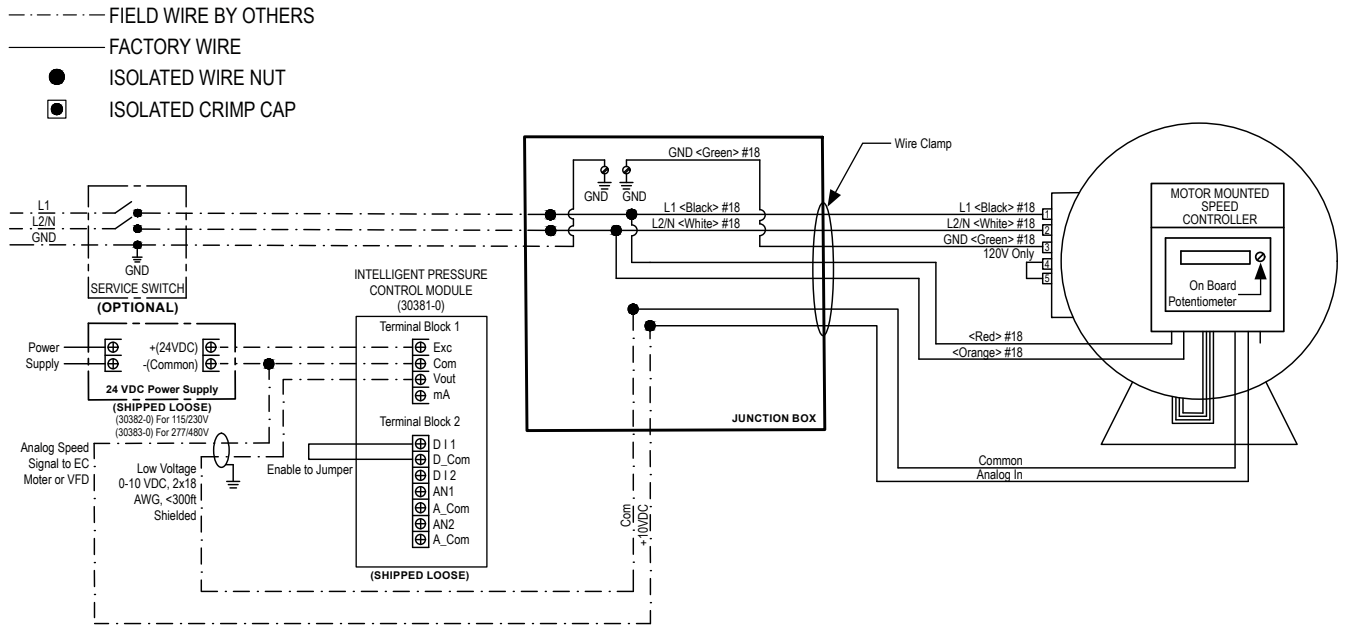

- Note. - 1. Voltage doubler leads to be connected only for 120V. Must be disconnected when 208-277V is used.
 2. To Use External speed control, turn motor mounted adjustment screw fully counter-clockwise (0%).
 3. For wiring instructions of external speed controller refer OEM catalog.
 4. Intelligent pressure controller can be purchased with or without a power supply.



P E N N B A R R Y TM

PennBarry is proud to be your preferred manufacturer of commercial and industrial fans and blowers. Learn how PennBarry can assist you in your next application by contacting your PennBarry Representative or visiting us on the web at www.pennbarry.com.

PennBarry | www.pennbarry.com | pbtsr@pennbarry.com | tel: 765.483.5800

PennBarry reserves the right to make changes at any time, without notice, to models, construction, specifications, options & availability. This manual illustrates the appearance of PennBarry products at the time of publication.

View the latest updates on the PennBarry website.

© 2021 PennBarry. All Rights Reserved. Revised NOVEMBER 2024